

CANCER

The cancer predisposition revolution

How was the inherited basis of cancer foreshadowed?

By David Malkin,¹ Judy E. Garber,² Louise C. Strong,³ Stephen H. Friend⁴

Studies of rare cancer predisposition syndromes often lead to the identification of genes critical to carcinogenesis. In 1969, Li and Fraumeni described a constellation of various cancers in the family members of four unrelated children who were diagnosed with soft tissue sarcomas (1). They posited that the cancers best fit an autosomal dominant pattern of inheritance, attributable to a genetic defect. At that time, cancer was not generally thought of as a genetic disease. Their hypothesis set the stage for establishing germline mutations in the tumor suppressor gene *TP53* as the underlying genetic event in Li-Fraumeni syndrome (LFS) families (2) (see the figure). It also foreshadowed dozens of discoveries, still ongoing, that associate mutations in tumor suppressor genes, activated oncogenes, mitochondrial genes, and DNA repair genes with cancer predisposition phenotypes in which multiple different neoplasms occur across generations.

What makes the prescience of Li and Fraumeni remarkable is how little was known at the time. Their observation preceded both Knudson's "two-hit" theory of carcinogenesis and the technical ability to look for heritable mutations in genes, and it was not until 1986 that the first cancer susceptibility gene, *Rb1*, was shown to be responsible for retinoblastoma, a rare heritable cancer (3). In 1979, two groups discovered the p53 oncoprotein (4–6). The field then exploded with seminal papers that paved the way for the ultimate discovery of the link between p53 and LFS: the "classic" clinical features of LFS were defined (7); inactivating somatic *TP53* mutations were discovered in a wide spectrum of cancers (8); and a *Trp53* transgenic mouse was created that facilitated further research (9).

Remarkably, well into the 21st century, not only do new genes continue to be discovered to account for long-known cancer syndromes [e.g., *protection of telomeres 1 (POT1)*;

¹Division of Hematology/Oncology, Hospital for Sick Children and Department of Pediatrics, University of Toronto, Toronto, Ontario M5G 1X8, Canada. ²Division of Population Sciences, Dana-Farber Cancer Institute, Harvard Medical School, Boston, MA 02215, USA. ³Department of Genetics, University of Texas M. D. Anderson Cancer Center, Houston, TX 77030, USA. ⁴Sage Bionetworks, Seattle, WA 98109, USA. Email: david.malkin@sickkids.ca

Pedigrees of Li-Fraumeni syndrome families with germline *TP53* mutation

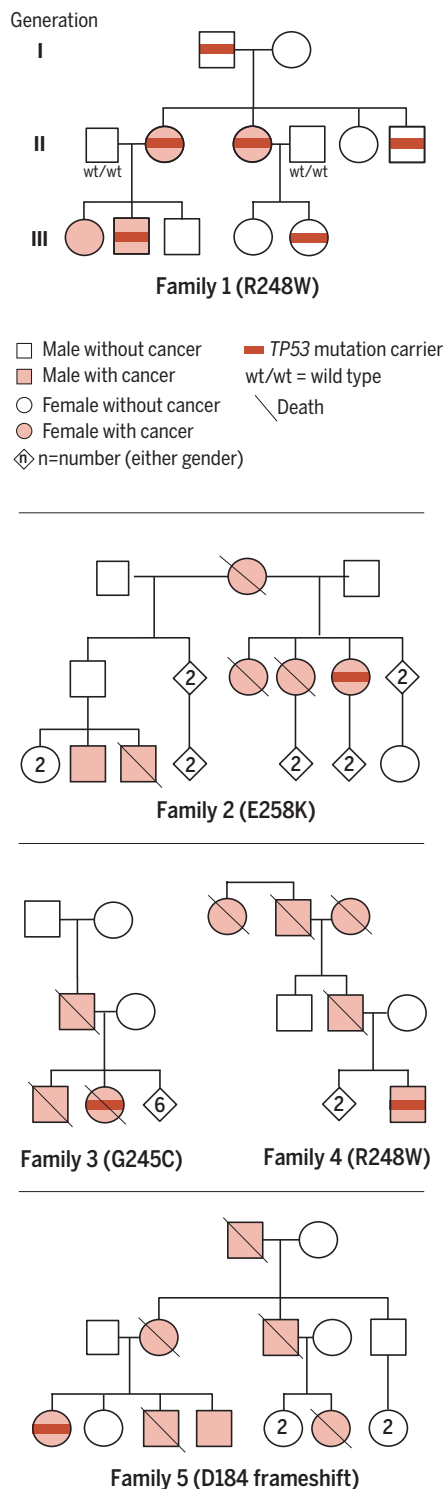

partner and localizer of BRCA2 (PALB2)], but new syndromes also continue to be defined. These include biallelic mismatch repair deficiency, in which early-onset cancers occur as a result of a perfect storm of inherited biallelic microsatellite gene mutations followed by somatic inactivation of a DNA polymerase (10), and DICER1 syndrome, in which an array of childhood and adult-onset tumors are caused by inactivation of a gene that is essential for microRNA processing (11). Thus, systematic clinical cancer epidemiology, as established by Li, Fraumeni, and Miller in the 1960s, continues to influence the discovery of cancer syndromes and cancer susceptibility genes and inform our understanding of the fundamental biology of human cancer.

Although different *TP53* mutations confer different degrees of penetrance, the overall lifetime risk of cancer is at least 75% in males and approaches 100% in females; the risk of developing multiple cancers is higher than in the general population by a factor of 85 (12). Despite progress in understanding the central role played by wild-type p53 in maintaining genome stability, and that of mutant p53 in cellular transformation, it is still nearly impossible to prevent or delay cancer in LFS, to predict age of onset, likelihood, or type(s) of cancers that will develop, to reduce the incidence of subsequent malignancies, or to optimally treat the cancers once they occur. Radiation-free clinical surveillance protocols may empower families to detect cancers early, offering hope for improved survival (13). However, the availability of whole-body magnetic resonance imaging (MRI) is limited in some jurisdictions because definitive evidence of efficacy is not yet available—a challenging problem in a rare syndrome. Whole-body MRI is being studied in many other cancer syndromes as well, particularly when cancer risk in childhood is a feature. Intensive screening efforts without risk reduction are fraught with additional challenges, including the establishment of detection precision, demonstration of definitive improvement in outcomes such as prolonged survival, and the complex psychological risk-benefit considerations of frequent examina-

The first families. Pedigrees of the first Li-Fraumeni syndrome families in whom germline *TP53* mutations were detected (1). The amino acid substitutions are shown for each family: C, Cys; D, Asp; E, Glu; G, Gly; K, Lys; R, Arg; W, Trp.

tions and potential false positives.

However, with the advent of affordable and rapid next-generation sequencing platforms, LFS germline and tumor genomes are being mapped with great precision. These efforts should reveal clues as to the genetic and epigenetic events that modify the effect of a *TP53* mutation on cancer phenotype. This information could lead to the development of more precise patient-specific algorithms to predict tumor type, which should lead to better surveillance strategies, perhaps including circulating tumor DNA and other biomarkers. Targeting the p53 signaling pathway with drugs offers opportunities to reprogram p53-dependent events, reengage wild-type p53 function, and reverse early p53-induced cellular transforming events. Animal models of p53 dysfunction to explore chemopreventive or therapeutic avenues are also critical to this line of discovery. Expanded access to comprehensive genetic data will permit more accurate mutation-specific penetrance estimates and more complete evaluation to correlate molecular alterations with pathogenicity.

Advances in LFS research have benefited from impressive international collaborative networks. Scientists studying the basic principles of p53 biology recognize the immense value of the LFS phenotype in understanding this fundamental cancer gene. At the same time, better syndrome recognition by physicians and expanded germline genetic testing have led to the identification of thousands of LFS families. The “glue” that keeps clinicians, clinician-investigators, and basic scientists working toward a common goal is the LFS families themselves. Through the international Li-Fraumeni Exploration (LiFE) Research Consortium or as individuals, patients contribute samples to research studies, share personal stories, and challenge the research community to address questions that are relevant to their lives. As the p53-LFS marriage enters its second quarter century, its history and evolution will continue to inspire and motivate all who work in the dynamic field of hereditary cancer. ■

REFERENCES AND NOTES

1. F. P. Li, J. F. Fraumeni Jr., *Ann. Intern. Med.* **71**, 747 (1969).
2. D. Malkin et al., *Science* **250**, 1233 (1990).
3. S. H. Friend et al., *Nature* **323**, 643 (1986).
4. D. I. Linzer, A. J. Levine, *Cell* **17**, 43 (1979).
5. D. P. Lane, L. V. Crawford, *Nature* **278**, 261 (1979).
6. M. Mowat et al., *Nature* **314**, 633 (1985).
7. F. P. Li et al., *Cancer Res.* **48**, 5358 (1988).
8. S. J. Baker et al., *Science* **244**, 217 (1989).
9. A. Lavigne et al., *Mol. Cell. Biol.* **9**, 3982 (1989).
10. A. Shlien et al., *Nat. Genet.* **47**, 257 (2015).
11. D. A. Hill et al., *Science* **325**, 965 (2009).
12. M. Hisada et al., *J. Natl. Cancer Inst.* **90**, 606 (1998).
13. A. Villani et al., *Lancet Oncol.* **12**, 559 (2011).

ACKNOWLEDGMENTS

Dedicated in memory of Frederick P. Li—physician, scientist, scholar, colleague, mentor, and great friend.

10.1126/science.aag0832

POLYMER SYNTHESIS

Organic photocatalysts for cleaner polymer synthesis

Metal-free catalysts enable synthesis of polymers for biomedical and electronics applications

By Sivaprakash Shanmugam and
Cyrille Boyer

The material properties of synthetic polymers can be tuned by changing their chain length and branching and the way in which monomer units repeat. For example, high-density polyethylene, which has little chain branching, is a stiff polymer used for food containers and drain pipes, whereas low-density polyethylene, which has more chain branching, is flexible and used to make grocery bags and bottles for chemicals. Polymers are usually made through thermal polymerization, but recent efforts focusing on green chemistry have led to a push toward using solar energy to drive chemical reactions. On page 1082 of this issue, Theriot et al. (1) report on metal-free visible-light photocatalysts that produce well-defined

“...this technique may become viable for synthesis of materials for industrial and biomedical applications.”

polymers free of metal contamination through radical polymerization.

Free-radical polymerization, in which a thermally decomposing radical initiates the addition of one monomer unit to another, is commonly used in industry. However, this approach cannot control chain length because of the rapid termination of growing chains. To ensure perpetual growth of polymer chains with homogeneous chain lengths, atom-transfer radical polymerization (ATRP) is commonly used (2–4). Unlike free-radical polymerization, ATRP generates chains with excellent chain-end func-

tionality, which enables reactivation for further monomer addition or even postpolymerization modification. Moreover, atom-transfer radical polymerization provides the means to generate polymers with predetermined molecular weight, narrow molecular weight distribution, and copolymer composition (5). By controlling these properties, a new range of high-value applications have emerged in diagnosis, nanomedicine, and nanotechnology (6).

Nevertheless, ATRP has required transition-metal catalysts, predominantly copper halides, which become part of the polymer. The Cu^I state activates polymerization, whereas Cu^{II} deactivates it, but unavoidable chain termination can lead to accumulation of Cu^{II}. Thus, relatively high Cu concentrations—10,000 parts per million (ppm)—are required to maintain the equilibrium between Cu^I and Cu^{II}. Alternative solutions, specifically ARGET (activators regenerated by electron transfer) atom-transfer radical polymerization, have been proposed to reduce the amount of Cu (from 10,000 to 10 ppm) through the use of organic reducing agents, such as ascorbic acid and glucose, that maintain the Cu^I and Cu^{II} equilibrium (2). Alternatively, the use of ion-exchange resin and absorbent, such as alumina, silica, or talcum, can further reduce the concentration of catalyst in the final polymer product (5).

Although Cu contamination can be minimized by these approaches, complete removal of this transition metal is necessary for applications involving microelectronics and biomaterials, which has spurred the development of metal-free catalyst systems. The recent work of the groups of Hawker and Matyjaszewski introduced control over atom-transfer radical polymerization through electrochemistry (7) and photochemistry [for selected examples and a review, see (8–10)]. Remarkable spatial, temporal, and sequence control has enabled fine tuning of the properties of the generated materials.

Realizing the potential of photochemical polymerization, Miyake and Theriot (11) initially explored the use of perylene as a photocatalyst for activation of photo-atom-transfer radical polymerization under visible light

Centre for Advanced Macromolecular Design (CAMD) and Australian Centre for NanoMedicine (ACN), School of Chemical Engineering, UNSW Australia, Sydney, NSW 2052, Australia. Email: cboyer@unsw.edu.au



The cancer predisposition revolution

David Malkin, Judy E. Garber, Louise C. Strong and Stephen H. Friend (May 26, 2016)

Science **352** (6289), 1052-1053. [doi: 10.1126/science.aag0832]

Editor's Summary

This copy is for your personal, non-commercial use only.

- Article Tools** Visit the online version of this article to access the personalization and article tools:
<http://science.sciencemag.org/content/352/6289/1052>
- Permissions** Obtain information about reproducing this article:
<http://www.sciencemag.org/about/permissions.dtl>

Science (print ISSN 0036-8075; online ISSN 1095-9203) is published weekly, except the last week in December, by the American Association for the Advancement of Science, 1200 New York Avenue NW, Washington, DC 20005. Copyright 2016 by the American Association for the Advancement of Science; all rights reserved. The title *Science* is a registered trademark of AAAS.